

PARTS LIST						
ITEM	QTY	PART NO.	PART DESCRIPTION	LENGTH	UNIT WT.	NET WT.
1	1	320600-I	1/2" x 12" JAW/JAW TURNBUCKLE		1.64	1.64
2	2	GC4095	1/4" x GR40 GALV. CHAIN		4.44	4.44
3	2	SHK38	3/8" SHACKLE		0.31	0.63
4	2	G1202	1/2" x 2" HDG HEX BOLT GR5	2 in	0.18	0.35
5	2	G12LW	1/2" HDG LOCKWASHER	1/8 in	0.01	0.03
6	2	EN12	1/2 EYE NUT		0.21	0.42
					TOTAL WT. #	7.55

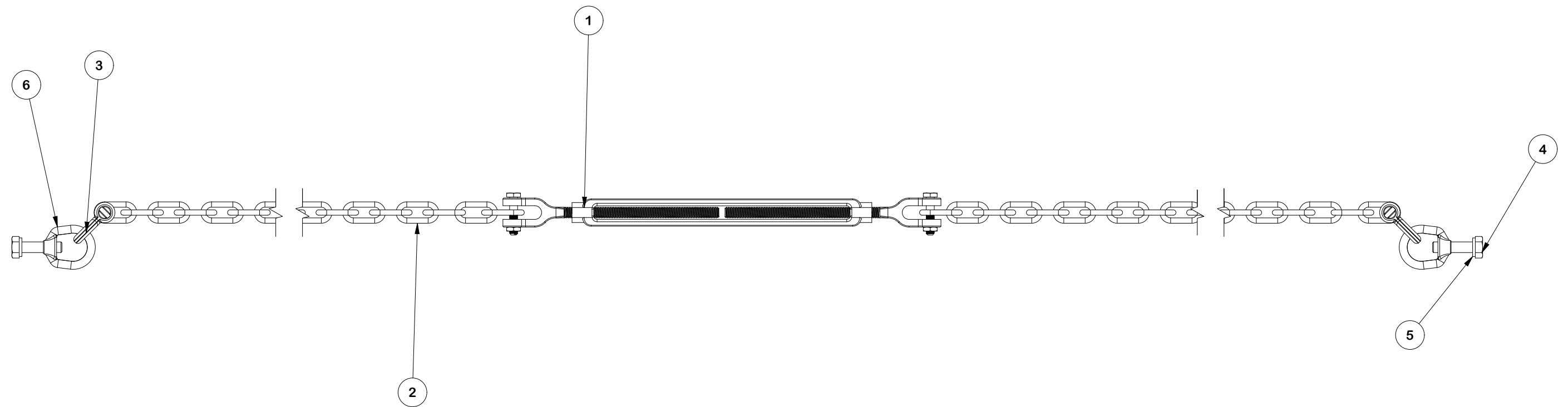

FINISH:
HOT DIP GALVANIZED.

TOLERANCE NOTES

TOLERANCES ON DIMENSIONS, UNLESS OTHERWISE NOTED ARE:
 SAWED, SHEARED AND GAS CUT EDGES ($\pm 0.030"$)
 DRILLED AND GAS CUT HOLES ($\pm 0.030"$) - NO CONING OF HOLES
 LASER CUT EDGES AND HOLES ($\pm 0.010"$) - NO CONING OF HOLES
 BENDS AND ANGLES ARE $\pm 1/2$ DEGREE
 ALL OTHER MACHINING ($\pm 0.030"$)
 ALL OTHER ASSEMBLY ($\pm 0.060"$)

PATENT INFORMATION: WWW.SITEPRO1.COM/PATENTS

PROPRIETARY NOTE:
 THE DATA AND TECHNIQUES CONTAINED IN THIS DRAWING ARE PROPRIETARY INFORMATION OF VALMONT INDUSTRIES AND CONSIDERED A TRADE SECRET. ANY USE OR DISCLOSURE WITHOUT THE CONSENT OF VALMONT INDUSTRIES IS STRICTLY PROHIBITED.

DESCRIPTION
BALLAST TIE DOWN KIT

CPD NO.	DRAWN BY	ENG. APPROVAL
	CMFL 7/28/2020	
CLASS	SUB	DRAWING USAGE
87	02	CUSTOMER
CHECKED BY		

SITE PRO 1
 A valmont COMPANY
 Engineering Support Team:
 sp1engineering@valmont.com

PART NO.	CSRT-BTD
DWG. NO.	CSRT-BTD